



vendor
development
group, inc

Offset Umbrella

Owner's Manual

For use with 9' and 10' offset umbrellas

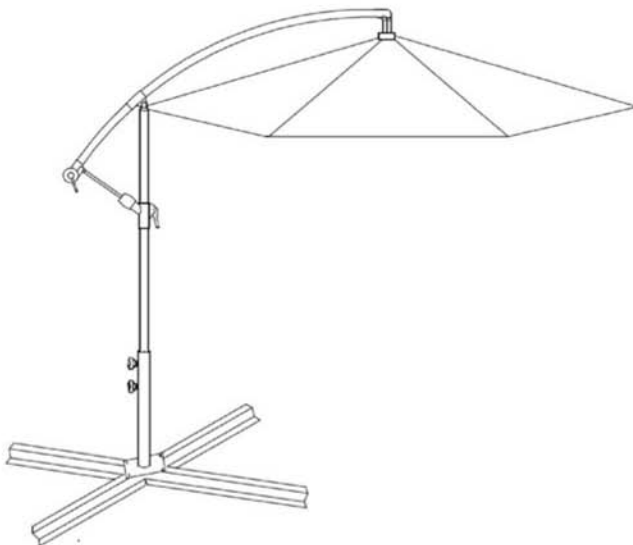

Read and follow all of these manufacturer instructions before beginning assembly or operation. Failure to do so could result in serious injury or death.



Keep this owner's manual for future reference. If you sell or give this product to someone else, make sure this manual accompanies this product.

Thank you for your purchase of this product. If any parts of this product are missing or were received damaged, or if you have questions concerning the safe assembly and use of this product,
PLEASE DO NOT RETURN THIS ITEM TO THE STORE.



Instead, please contact us via e-mail at:
customerservice@vendord.com

Or, call our toll-free customer service line at:

1-866-561-0731

(Monday through Friday, 8:30AM – 4:30PM CST)

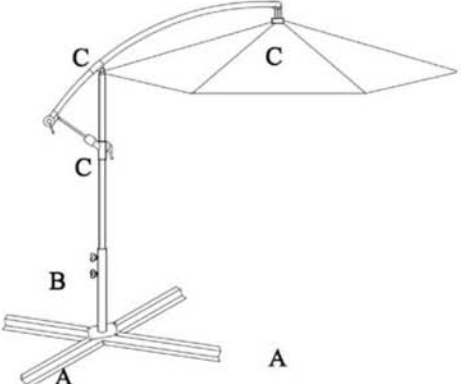
PARTS / HARDWARE / TOOLS

| | | |
|---|---|---|
| A | Base Legs (2) |  |
| B | Mounting Tube (1) | |
| C | Umbrella Assembly (1) | |
| 1 |  Wrench (1) | |
| 2 |  15mm Bolts (4) | |
| | | |

PREPARATION

Remove all parts and hardware from the carton and place them on a clean soft surface. Make sure nothing is missing. Dispose of all packaging materials properly. Please recycle whenever possible.

ASSEMBLY

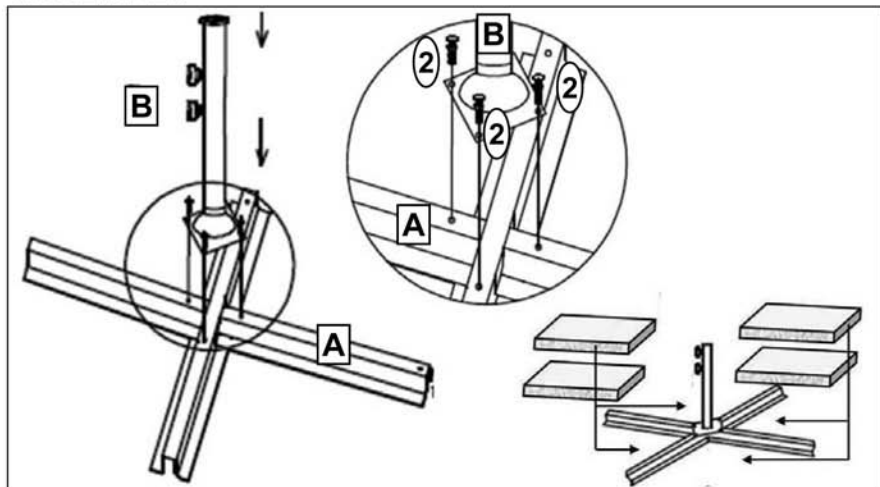

STEP 1. Set one Base Leg (A) over the other so the slots interlock. Align the holes in the Mounting Tube (B) plate with the holes in the base legs. Thread one Bolt (2) into each hole and tighten securely with the Wrench (1). Place pavers, sandbags, or other weights (not included) weighing at least 100 pounds on the base to prevent the umbrella from tipping.

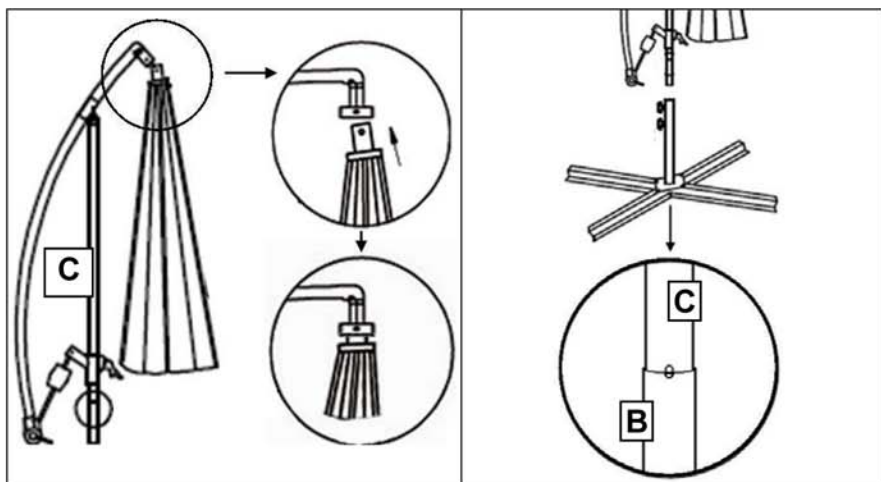

STEP 2. Locate the canopy joint of the Umbrella Assembly (C). Slide the canopy tube into the plastic receiver until the spring buttons click into place. Now, carefully set the pole of the Umbrella Assembly (C) into the Mounting Tube (B) so the two small posts rest in the notches of the Mounting Tube (B). Tighten the lock knobs securely to keep the pole in place.

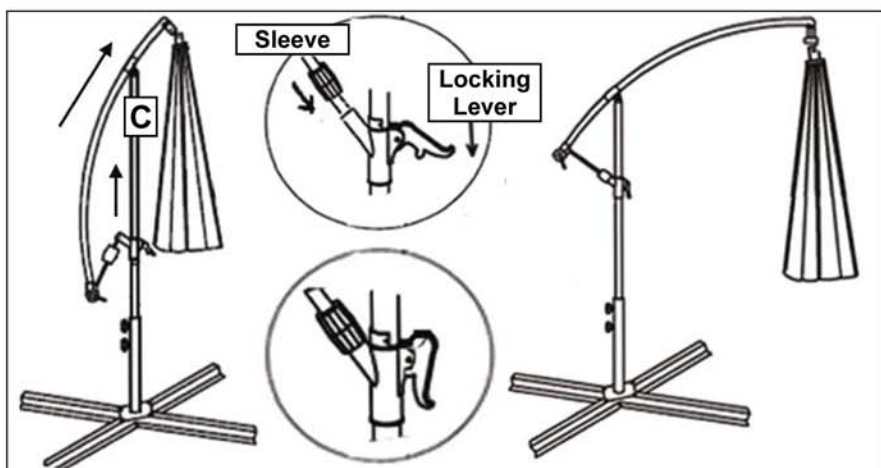

STEP 3. Slide the canopy support pole and locking lever assembly upward until they meet the plastic stoppers. Slide the sleeve over the post and clamp the locking lever down firmly. Use care to avoid pinching. Always loosen the locking lever and slide the sleeve off the post before moving or adjusting the support pole.

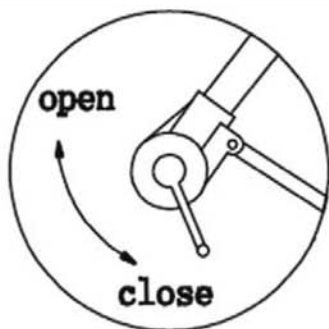

STEP 4. Turn the crank to open or close the umbrella canopy. Do not over-crank the canopy or damage may occur. Close the canopy before lowering the canopy support bar.

⚠ WARNING

Check all fasteners before each use to make sure they are tightened securely! Failure to do so could result in serious injury!

⚠ WARNING

Always place 100 lbs. of weight on the base. Failure to do so could cause the umbrella to tip over and could result in serious injury.

⚠ WARNING

Avoid injury and damage! Never use the umbrella during strong wind or storms. Always use this product on a sturdy level surface.

CARE INSTRUCTIONS

Wipe clean with a slightly damp cloth. Never use abrasive cleansers. For longer life, store indoors when not in use.

LIMITED WARRANTY

This product is for residential use only. Any commercial use of this product voids all warranties, and frees the manufacturer from all liability. This warrants to the original purchaser that this product is free from defects in material and workmanship as of the date of purchase and that it will, under normal use and proper care, remain so for 180 days from the date of purchase. Missing or initially defective parts will be replaced free of charge during the entire period of this limited warranty. Replacement parts will be shipped at no charge to the consumer. Proof of purchase (dated receipt) may be required for warranty claims.

This warranty does not cover damage which has occurred during transport from the point of purchase to the consumer's home. This warranty does not cover products that have been assembled incorrectly, improperly cared for, modified or altered, misused or abused in any way. The external surfaces of this product have been treated to help provide protection from exposure to the elements. However, natural weathering (including but not limited to, fading, rusting, staining, etc.) will occur, and are not covered by this limited warranty.