

DECK MOUNT PLATE - INSTALLATION

HARDWARE AND TOOLS REQUIRED:

⇒ on wooden sundecks

- Drill with ¼" drill bit
- 2 galvanized lag screws 3/8" x 4", 2 galvanized lag screws 3/8" x 2 1/2", 4 galvanized washers 3/8"
- Ratchet with ½" socket

INSTALLATION PROCEDURE:

- Place plate on the deck with 2 of the mounting holes centered over a deck joist. Mark all 4 holes and pre-drill with the ¼" bit. (See enclosed drawing for details)
- Use the 4" lag screws to fasten the plate through the decking into the joist. It may be helpful to lubricate the screws before inserting them.
- Use the 2 1/2" lag screws to fasten the plate to the 2x4 or 2x6 running perpendicular to the joist. On decks accessible from underneath, it is preferable to use 3/8" x 3" hex bolts with a nut and large washer below the deck.
- **IMPORTANT:** Tighten the screws well, but to not use excessive force. On new (green) sundecks, occasional re-tightening may be required due to shrinkage of the lumber.

HARDWARE AND TOOLS REQUIRED:

⇒ on concrete patios

- Hammer drill (e.g. Hilti) with ½" concrete bit
- 4 concrete spread anchors, 4 3/8" x 2" mounting bolts with washers. Consult with your building supply specialist for proper combination of anchors and bolts to achieve a minimum pullout strength of 200 lbs. per anchor.
- Ratchet with ½" socket

INSTALLATION PROCEDURE:

- Place plate on the concrete making sure it is not tipping or riding on a high spot. Check plate with a level, shim if necessary.
- Mark fastening holes, drill to proper depth.
- Fasten plate with bolts into anchors

Deckmount Plate - correct placement

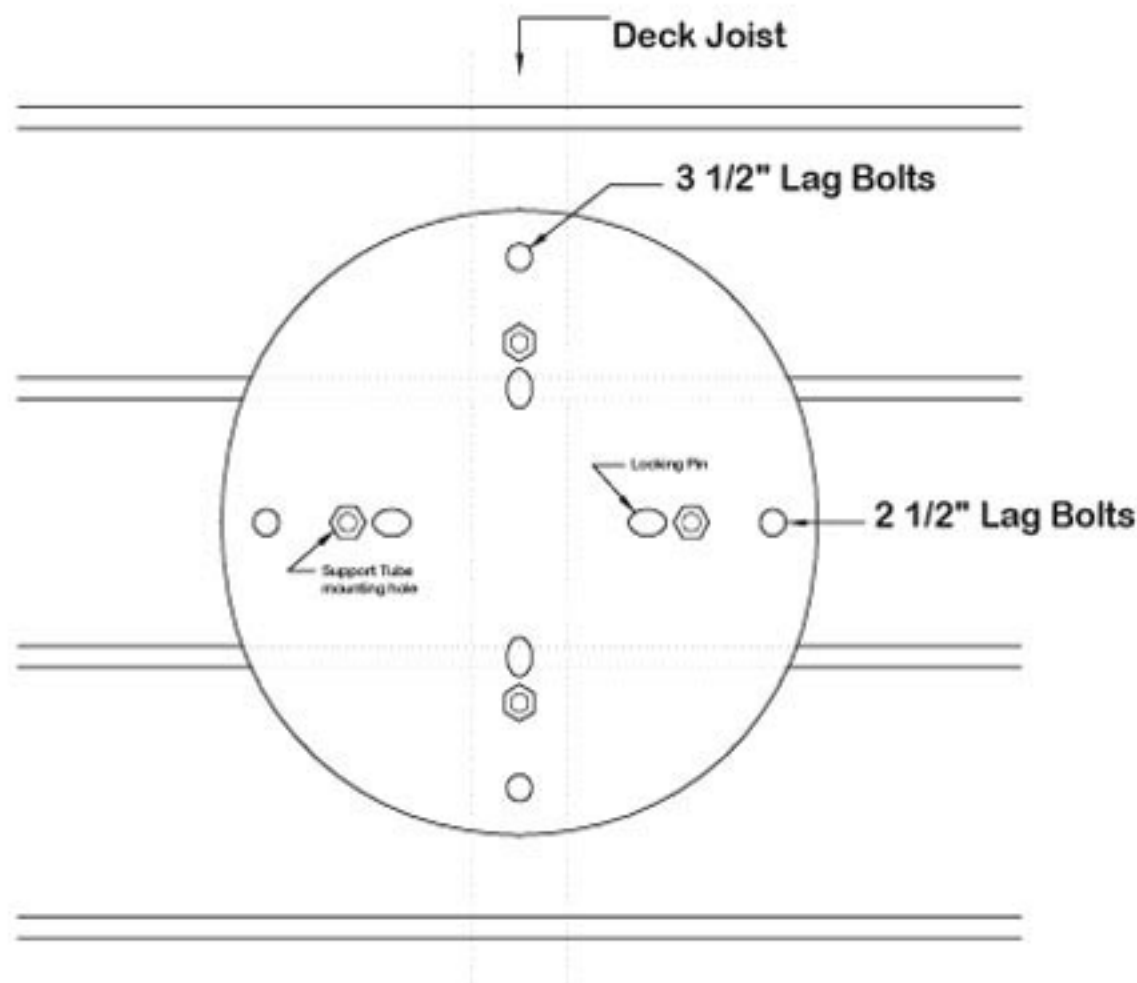

GROUND INSERT BASE - INSTALLATION

MATERIALS AND TOOLS REQUIRED:

- 1-2 bags of quick set ready mix concrete (please consult with your building supply store for exact quantity)
- 2 gallon mixing bucket
- small hand shovel or trowel
- 1 piece of 2x6, 18-20" long
- 2 - 4" C-clamps
- Carpenters Level

INSTALLATION PROCEDURE:

1. Clamp the ground insert base with the flat top plate to the center of the 2x6
2. Determine exact location for the umbrella base.
3. **VERY IMPORTANT: The umbrella rotation disk 'O' allows for a number of fixed positions in a full 360° Circle. If you need to position and lock the umbrella over an exact spot (e.g. the center of a table), make sure to orient the ground insert sleeve so it allows you to properly lock the umbrella in place with the locking pin 'U' at that specific location.**
4. Once the proper location and orientation for the base have been established, prepare a hole approximately 10x10" square and 18" deep, and fill it with quick-set ready-mix concrete (Sakrete) to about 1" below the surface level. Make sure to follow the mixing instructions carefully.
5. Push the ground sleeve into the mixture and agitate it with quick, short strokes it so the concrete will bond to the metal. Lower the sleeve until the 2x6 rests on the ground surrounding the hole. This way it is assured that the top of the plate is flush with the ground once the concrete has set.
6. Take a water level to check if the top of the 2x6 is exactly level *in all directions (!)* If it is not, simply use shims or wedges to raise the board where necessary. Complete this step carefully, as the umbrella post might appear to "lean" if the base is not installed plumb.
7. Let the concrete set overnight. Remove the board and make sure not to knock the sleeve hard (concrete takes up to 7 days to cure). Cover the open screw holes on top of the base plate with masking tape.
Fill the remaining space up to the top plate with some ready mix. Tap it in nicely, and finally drag your 2x6, held on edge, across the base with a zigzag motion to smooth the surface. Let it sit for a few hours and then clean off the top plate with a damp cloth. Make sure to let the concrete cure for at least 3 days in warm conditions, and up to 7 days if the temperature is below 50deg. Fahrenheit /10deg. Celsius

